

# SALINI

---

## OVEN BUILT IN **Instruction Manual**

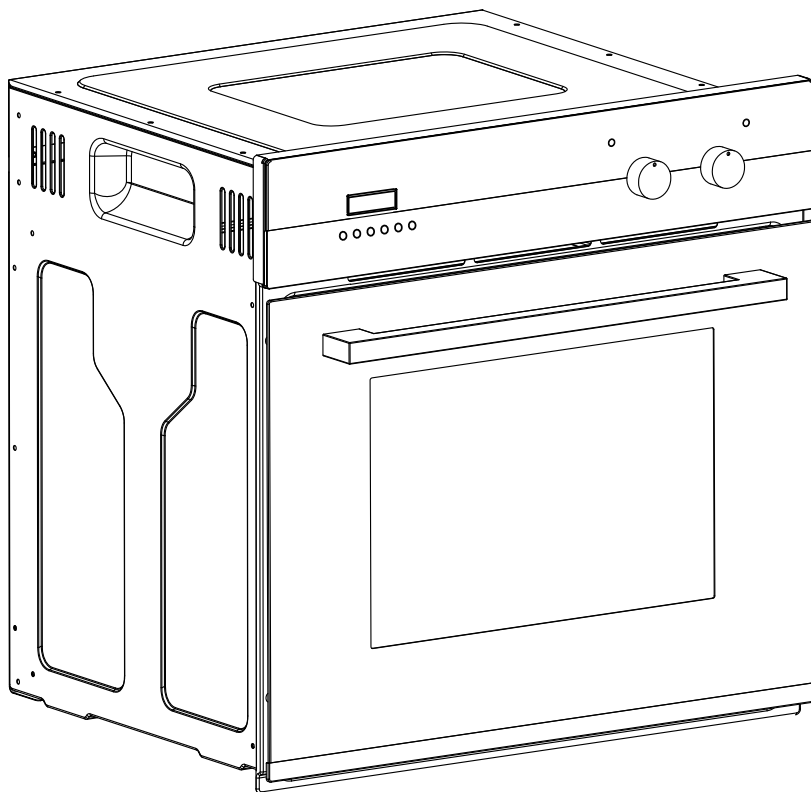

**SOB-1002H**

[WWW.SALINI.COM.AU](http://WWW.SALINI.COM.AU)

# CONTENTS

<b>Important safety information</b>	<b>2-5</b>
<b>Description of the appliance</b>	<b>6-8</b>
Inserting accessories	7
Control panel	8
<b>Using your appliance</b>	<b>9-14</b>
Oven programmer/timer	9
Selecting an oven function	11
Setting the temperature	12
Setting and using the end cook/end time function	13-14
<b>Cleaning and maintenance</b>	<b>15-18</b>
Removing accessories and door	17
Lamp replacement	18
<b>Avoiding damage from misuse</b>	<b>19</b>
<b>Installation</b>	<b>20-25</b>
Electrical connections	21
Installing the oven into the kitchen cabinet	22
Ventilation requirements	25
<b>Troubleshooting</b>	<b>26-27</b>
<b>Cooking Recommendations</b>	<b>28-30</b>
<b>Technical data</b>	<b>31</b>
<b>Declaration of conformity</b>	<b>32</b>

## IMPORTANT:

This User Instruction Manual contains important information, including safety & installation points, which will enable you to get the most out of your appliance. Please keep it in a safe place so that it is easily available for future reference; for you or any person not familiar with the operation of the appliance.

# IMPORTANT SAFETY INFORMATION



## CAUTION!

Do not use or attempt to install this appliance until you have read this instruction manual. This appliance is intended for household use only.

## General Information

- This appliance is designed for domestic household use and designed be built into a standard kitchen cabinet or housing unit.
- **IMPORTANT:** Your product warranty will be void if the installation is not in accordance with the instructions. The installation must be carried out by a suitably qualified person, in accordance with the with the manufacturer's instructions, and must be connected in accordance with all local electrical rules specification.
- The use of this appliance for any other purpose or in any other environment will void warranty.
- Your new appliance is guaranteed against electrical or mechanical defects, subject to certain exclusions, the foregoing does not affect your statutory rights.
- Repairs may only be carried out by Service Engineers or an authorised service agent.
- Check the appliance for damage after unpacking it. Do not connect or install the appliance if it has been damaged in transport as this will void the warranty.

## Warning and safety instructions



### WARNING:

The appliance and its accessible parts become hot during use. Care should be taken to avoid touching heating elements.

- This appliance complies with all current Australian and European safety legislation, and designed to operate safely in normal use, however the appliance surfaces will become hot during use and retain heat after operation.
- This appliance is not intended for use by persons (including children) with reduced physical, sensory or mental capabilities, or lack of experience and knowledge, unless they have been given supervision or instruction concerning use of the appliance by a person responsible for their safety.
- During use the appliance becomes hot. Care should be taken to avoid touching heating element inside the oven.
- Always use heat resistant oven gloves when handling food, dishes, shelves, trays or ovenware when the oven is still on or retaining heat from recent use.
- Never touch the hot burners, inner sections of the oven, heating elements etc.

- When the oven is on, or still retaining heat, use caution when opening the oven door, always allow enough distance for hot air and steam to escape before to avoid injury when handling food.
- **WARNING:** Accessible parts may become hot during use. Young children should be kept away.

## Electrical Caution



**WARNING!** Cleaning operations must only be carried out when the oven is cool and disconnected from the power supply.

- Any work on electric equipment and systems may only be carried out by authorized qualified persons.
- Even if the oven is off, the cooling fan continues working for a while after turning off the oven.
- In case of any damage, switch off the appliance and disconnect it from the power supply
- If the supply cord is damaged, it must be replaced by the manufacturer, its service agent or similarly qualified persons in order to avoid a hazard.
- **WARNING:** Ensure that the appliance is switched off before replacing the lamp to avoid the possibility of electric shock.

## Child Safety

- **WARNING:** Accessible parts may become hot during use.
- We strongly recommend that babies and young children are prevented from being near to the appliance and not allowed to touch the appliance at any time.
- If it is necessary for younger family members to be in the kitchen, please ensure that they are kept under close supervision at all times.
- When the door is open, do not allow children to sit or lean onto it. It may overturn causing harm and the door hinges may get damaged.
- Cleaning and user maintenance shall not be carried out by children without supervision.
- The packaging materials will be dangerous for children. Keep the packaging materials away from children. Please dispose of all parts of the packaging according to environmental obligation.

## Cleaning

- **WARNING!** The appliance must be disconnected from the power supply before cleaning
- Cleaning of the oven should be carried out on a regular basis.
- Great care should be taken whilst using this appliance and when following the cleaning procedure (*See Cleaning and Maintenance section*)
- Do not use harsh abrasive cleaners or sharp metal scrapers to clean the oven door glass since they can scratch the surface, which may result in shattering of the glass.
- A steam cleaner is not be used on any part of the oven.

## General Safety of Use

- DO NOT use the appliance for any other purpose than its intended use.
- DO NOT place heavy objects on the oven door or lean on the oven door when it is open, as this can cause damage to the oven door hinges.
- DO NOT leave heated oil or fat unattended, as this is a fire risk.
- DO NOT place pans, baking trays, dishes or aluminium foil directly onto the bottom of the oven. The heat accumulation might damage the bottom of the oven.
- DO NOT allow electrical fittings or cables to come into contact with areas of the appliance that get hot.
- DO NOT pour water into the hot cooking compartment.
- DO NOT use the product with the front door glass removed or if glass is cracked.
- DO NOT place greaseproof paper loosely over accessories during preheating. Always weight down the greaseproof paper with a dish or a baking tin. Only cover the surface required with greaseproof paper. Greaseproof paper must not protrude out and make contact with element.
- A draught is created when the appliance door is opened. Greaseproof paper may come into contact with the heating element as it may catch fire.
- The drip tray handle should only be used to reposition the drip tray and NOT for removing it from the oven cavity. When removing the drip tray, you should ALWAYS use an oven glove.
- Only use the temperature probe recommended for this oven.

## Installation



The installation must be carried out by a suitably qualified person, in accordance with the with the manufacturer's instructions, and in accordance with all local electrical and building rules and specifications.

- The appliance is intended for installation into kitchen cabinet or enclosure, it is important to follow instructions to ensure correct installation. Improper installation will void the product warranty, and invalidate any claims.
- We decline any responsibility for injury or damage, to person or property, as a result of improper use or installation of this appliance.
- Heat, steam and moisture will be created during use of the appliance, take care to avoid injury and ensure that the room is adequately ventilated. If the appliance is going to be used for prolonged periods of time, then additional ventilation may be required.
- Please consult with your qualified installer if you are in any doubt about the amount of ventilation that you will require.
- Carry the appliance with at least two persons, appliance is heavy and requires two persons lift
- DO NOT attempt to lift or move cooking appliances by using the oven door or handle, as this may cause damage to the appliance or result in injury to the person lifting the appliance.
- DO NOT install the appliance next to curtains or soft furnishings.
- **IMPORTANT:** The adjacent furniture or housing and all materials used in the installation must be able to withstand a minimum temperature of 85°C above the ambient temperature of the room it is located in, whilst in use.

# DESCRIPTION OF THE APPLIANCE

## Oven Overview

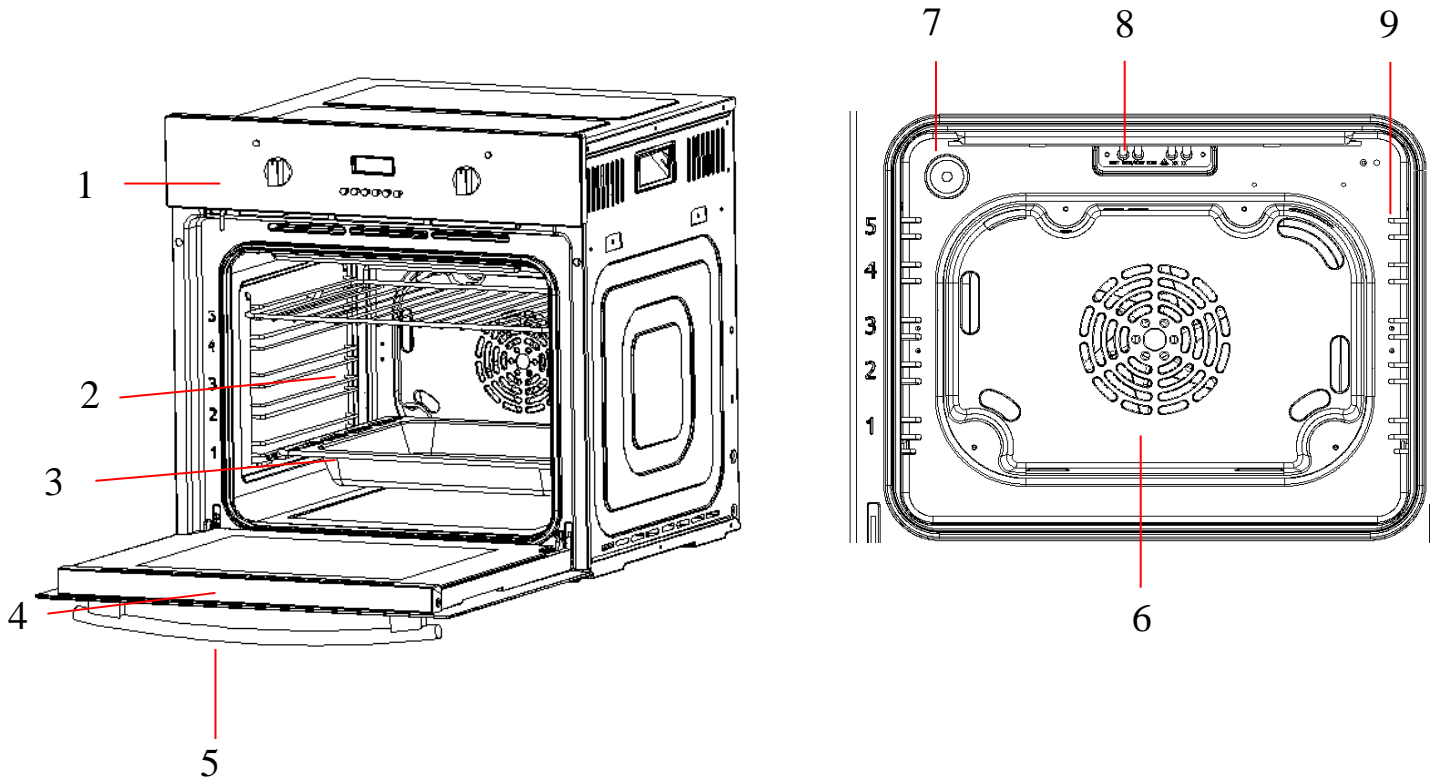

- 1. Control panel
- 2. Wire shelf
- 3. Tray
- 4. Door
- 5. Handle

- 6. Fan motor
- 7. Lamp
- 8. Grill heating element
- 9. Shelf positions

## Accessories

The accessories supplied with your appliance are suitable for making various meals. Ensure that you always insert the accessories into the cooking compartment in the correct way.

There is also a selection of optional accessories, with which you can improve on some of your favorite dishes, or simply to make working with your oven more convenient.

## Inserting accessories

You can insert the accessories into the cooking compartment at 5 different levels. Always insert them as far as they will go so that the accessories do not touch the door panel.

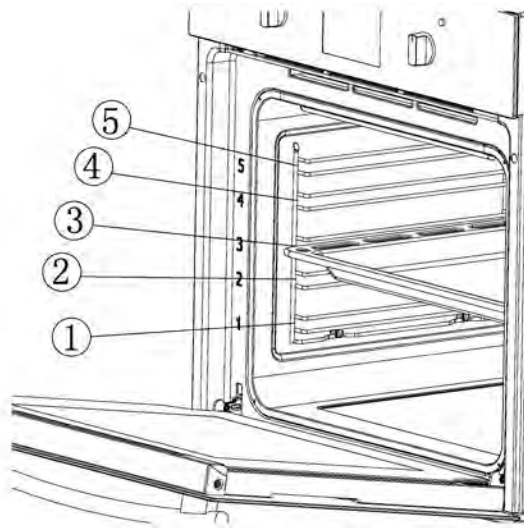

The accessories can be pulled out approximately halfway until they lock in place. This allows dishes to be removed easily.

**Note:** The accessories may deform when they become hot. Once they cool down again, they regain their original shape. This does not affect their operation.

## Oven pan

For moist cakes, pastries, frozen meals and large roasts. It can also be used to catch dripping fat when you are grilling directly on the wire rack.



## Wire rack

Used for roasting and for placing the food to be baked, roasted or cooked in casserole dishes.

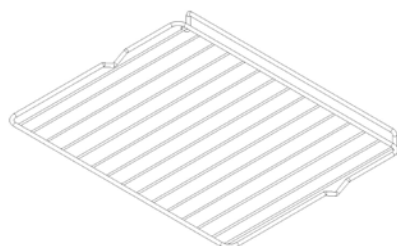



## Control panel

Here, you will see an overview of the control panel. Depending on the appliance model, individual details may differ.

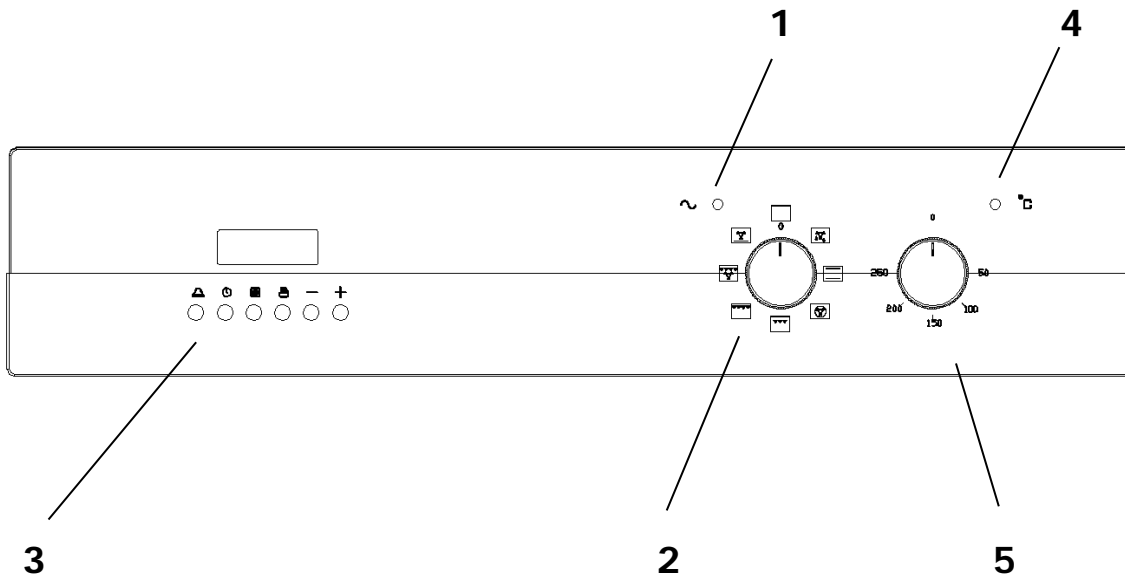

1. Power Indicator Light
2. Function Selector
3. Timer
4. Oven Operating Light
5. Temperature Control
6. Heating Indicator Light

## Cooling fan

A tangential cooling fan is fitted inside this appliance to keep the internal temperature of the oven stable and the external surface temperature lower. After the oven has been turned off the cooling fan will run on for a period of time until the oven is sufficiently cooled.

## USING YOUR APPLIANCE

This multi-function oven combines the advantages of traditional convection ovens with those of the more modern fan assisted models in a single appliance.

It is an extremely versatile appliance that allows you to choose easily between different cooking modes. (Take the time to read this section and familiarize yourself with its ability and functions to help you get the best out of using your appliance.)

### Before using the oven for the first time

We strongly recommend running the oven to air it out before you use it the first time.

To air it out, we recommend that it is set at the highest setting and leave the oven on for about half an hour with nothing in it, with the oven door shut. Then open the oven door and let the room air in. The odour that is often detected during this initial use is due to the evaporation of substances used to protect the oven during storage and until it is installed.

Before you use the accessories for the first time, clean them thoroughly with hot soapy water and a soft dish cloth.

### Setting and using the oven programmer/timer

#### Selecting manual operation mode

After your appliance is connected to your mains supply for the first time, the numbers on the timer display will flash. Before you can select a cooking function or set a temperature, you must set the appliance into "manual operation" mode.

- To select manual operation mode, press the "manual operation" button **(5)** on the control panel.

#### Setting the time of day

After setting your oven for manual operation, you should also set the time of day:

- After pressing the "manual operation" button **(5)**, use the "minus" button **(6)** and "plus" button **(7)** to adjust the time that appears in the display. After getting the display to the correct time, release the "minus" and "plus" buttons. After a few seconds the time will fix in the display and you will be able to use your oven.

## The oven timer

1. Oven programmer/timer
2. Timer "minute minder" button
3. Timer "duration" button
4. Timer "end cook" button
5. Timer "manual operation" button
6. Timer "minus" button
7. Timer "plus" button

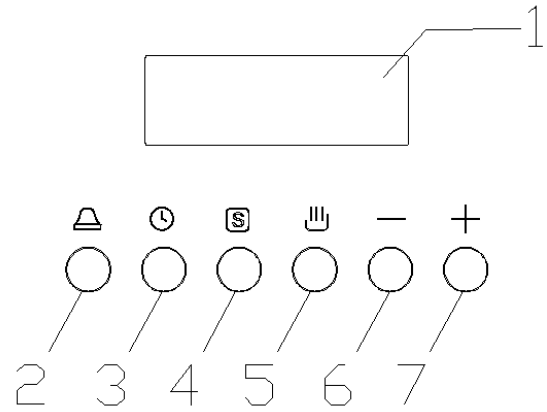

## Oven programmer/timer display

8. "Auto" function symbol
9. "Minute minder" symbol
10. "Manual operation" symbol.

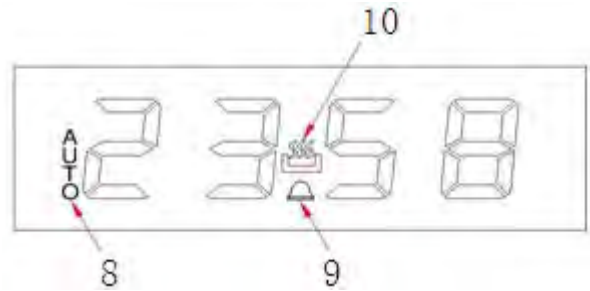

# Selecting a cooking function and temperature

## Selecting an oven function



The oven function selector knob should be used to select the particular mode of cooking that you require. The appliance will utilize different elements within the oven cavity, depending on the oven function that you select. When a function is selected, the power indicator light will come on.



### **Defrost:**

The fan runs without heat to reduce defrosting time on frozen foods. The time required to defrost the food depends on the room temperature.



### **Conventional Oven (top and lower element):**

This method of cooking provides traditional cooking, with heat from the top and lower elements. This function is suitable for roasting and baking on one shelf only.



### **Fan Forced:**

This method of cooking uses the circular element and the heat is distributed by the fan. This results in a faster more economical cooking process. The fan oven allows food to be cooked simultaneously on different shelves.



### **Half Grill:**

This method of cooking utilises the inner part only of the top element, which directs heat downwards onto the food. This function is suitable for grilling small portions of bacon, toast and meat etc.



### **Full Grill:**

This cooking method is for normal grilling using inner and outer parts of top element. It's ideal for medium to large portions of sausages, bacon, fish etc.



### **Fan Grill:**

The fan circulates heat from the oven grill around the food, simultaneous quick browning and sealing the juices in economical rotisserie or spit effect.



### **Fan and Bottom Element:**

This method of cooking utilises the bottom element in conjunction with the fan, which helps to circulate the heat. This function is suitable for sterilizing and reserving jars.

## Selecting an oven temperature

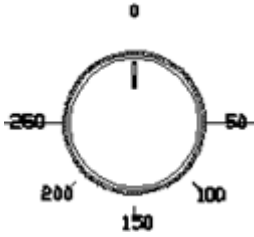

The oven thermostat control knob sets the required temperature of the oven. It is possible to regulate the temperature within a range of 50 - 250°C.

**Turn the control knob clockwise.**

## Setting the minute minder function

*You are able to set the minute minder at any time, regardless of whether an oven function has been selected. You can set a period of time using the minute minder function and an alarm will sound when that period of time has elapsed.*

- Press the "minute minder" button **(2)**, the display will show a value of 00:00. Set the period of time that you wish the minute minder to countdown for, by using the "minus" **(6)** and "plus" **(7)** buttons.
- Once the display has got to your desired countdown time, let go of the "minus" and "plus" buttons. The minute minder symbol **(9)** will appear on the timer display.
- Once a countdown time has been set, it is possible to shorten or lengthen the time by using the "minus" or "plus" buttons.
- An alarm will sound when the countdown time has elapsed. The alarm can be silenced by pressing the "minute minder" button.
- **IMPORTANT:** The oven will continue to heat once the alarm has been silenced. If you have finished cooking, then you should turn the oven function selector and thermostat control knob to 0.
- **NOTE:** Only the minute minder can be used with the defrost oven function. Any of the other timer settings will not work with the defrost oven function.

## Setting the duration function

*This function will allow you to set a countdown time similar to the minute minder function. However the oven will no longer continue to heat, once the countdown period has elapsed.*

- Use the thermostat control knob (Temperature selector) to set the temperature that you require. The manual operation symbol **(10)** will appear on the display.
- Use the oven function selector knob to select the mode of cooking that you require.
- It is then possible to set the duration of the cooking time that you require.

- Press the “duration” button **(3)** and the display will show a value of 00:00. Set the period of time that you wish the duration function to countdown for, by using the “minus” **(6)** and “plus” **(7)** buttons.
- Once the display has got to your desired countdown time, let go of the “minus” and “plus” buttons. The countdown will start immediately and the word AUTO will appear on the timer display.
- Once a countdown time has been set, it is possible to shorten or lengthen the time by using the “minus” or “plus” buttons.
- An alarm will sound when the countdown time has elapsed and the oven will switch off. The word AUTO will flash and the heating symbol will disappear. The alarm can be silenced by pressing the “duration” button.
- You will need to return the oven to manual operation mode, once the duration function has been used. To do this you should press the “manual operation” button, the word AUTO will disappear from the display and the manual operation symbol will appear instead.
- **IMPORTANT:** If you do not turn the thermostat control knob (Temperature selector) and oven function selector knob to 0, then the appliance will continue to operate as soon as you press the “manual operation” button.

## Setting the end cook function

*This function is similar to the duration function, however instead of selecting a period of time that you wish the oven to switch off after. You select the time of day that you wish the oven to switch off at.*

- Use the thermostat control knob (Temperature selector) to set the temperature that you require. The manual operation symbol **(10)** will appear on the display.
- Use the oven function selector knob to select the mode of cooking that you require.
- Press the “end cook” button **(4)** and the display will show a value of 00:00. Set the time of day that you wish the oven to stop cooking at by using the “minus” and “plus” buttons. The timer will calculate how long the cooking time will be, based on the time of day that you have selected and show it on the display.
- Once the display has got to the time of day that you want the oven to stop cooking at, let go of the “minus” and “plus” buttons. The countdown will start immediately and the word AUTO symbol will appear on the timer display.
- When the time is set, it can be modified by pressing the “minus” and “plus” buttons.
- When the time of day reaches the end of cooking time that you set, the oven will switch off and an alarm will sound. The word AUTO will flash and the heating symbol will disappear. The alarm can be silenced by pressing the “end cook” button.

- You will need to return the oven to manual operation mode, once the end cook function has been used. To do this you should press the “manual operation” button, the word AUTO will disappear from the display and the manual operation symbol will appear instead.
- **IMPORTANT:** If you do not turn the thermostat control knob and oven function selector knob to 0, then the appliance will continue to operate as soon as you press the “manual operation” button.

## Setting the start and end time function

*This function will allow you to set a time in the future that the oven switches on at and a time that the oven will switch off at.*

- Use the thermostat control knob (Temperature selector) to set the temperature that you require. The manual operation symbol (10) will appear on the display.
- Use the oven function selector knob to select the mode of cooking that you require.
- Press the “duration” button (3) and the display will show a value of 00:00. Set the period of time that you wish to cook for, by using the “minus” (6) and “plus” (7) buttons. The word AUTO will appear on the timer display.
- **Immediately** press the “end cook” button (4) and the timer display will show the value 00:00. Set the time of day that you want the oven to switch off at, using the “minus” and “plus” buttons.
- The oven will calculate what time it needs to switch on at, so that your food will cook for the length of time that you selected. It will automatically switch itself on, once it reaches the time of day that you set previously.
- When the time of day reaches the end of the cooking time that you set, the oven will switch off and an alarm will sound. The word AUTO will flash and the heating symbol will disappear. The alarm can be silenced by pressing the “end cook” or “duration” button.
- You will need to return the oven to manual operation mode, once the start and end time function has been used. To do this you should press the “manual operation” button, the word AUTO will disappear from the display and the manual operation symbol will appear instead.
- **IMPORTANT:** If you do not turn the thermostat control knob and oven function selector knob to 0, then the appliance will continue to operate as soon as you press the “manual operation” button.

## CLEANING AND MAINTENANCE



**CAUTION!** Cleaning operations must only be carried out when the oven is cool and disconnected from the power supply.

- The oven should be cleaned after every use. When cleaning the oven the lighting should be switched on to enable you to see the surfaces better.
- The oven cavity should only be cleaned with warm soapy water, using either a sponge or soft cloth. No abrasive cleaners should be used.
- After cleaning the oven cavity wipe it dry.
- Outer parts of the oven should only be cleaned with warm soapy water, using either a sponge or soft cloth. No abrasive cleaners should be used.
- If you use any form of oven cleaner on your appliance, then you must check with the manufacturer of the cleaner that it is suitable for use on your appliance.
- **DO NOT** clean the oven surfaces by steam cleaning.
- Any damage that is caused to the appliance by a cleaning product is not included under the product warranty, even if the appliance is within the warranty period.

### Advice to help reduce cleaning required

- Any stains that may appear on the bottom of the oven will have originated from food splashes or spilt food, these splashes occur during the cooking process. These could possibly be a result of the food being cooked at an excessively high temperature or being placed in cookware that is too small.
- You should select a cooking temperature and function that is appropriate for the food that you are cooking.
- You should also ensure that the food is placed in an adequately sized dish and that you use the drip tray where appropriate.



**CAUTION!** Do not use cleaning products containing abrasive materials for the cleaning and maintenance of the oven including the glass front panel.



## Regular inspections

Besides keeping the appliance clean, you should:

- Carry out periodic inspections of the control elements and cooking units of the cooker. After the warranty period has expired you should have a technical inspection of the cooker carried out at a service centre at least once every two years.
- Fix any operational faults.
- Carry out periodical maintenance of the cooking units of the cooker.
- If the sealing strip is not sealing adequately, it must be replaced with the same sealing strip. Do not use any other sealing strip instead as doing so may effect function performance.



**CAUTION!** All repairs and regulatory activities should be carried out by the appropriate service centre or by an appropriately authorized person.

## Removing accessories

You need to take out the accessories before you start cleaning the oven.

- 1) Remove the side shelves in the following way. Grab the bottom line of one side shelf, pull sideward, then pull upward, then lift the side shelf horizontally, and then pull out the side shelf.
- 2) Clean the cavity, and then put the side shelves back.
- 3) Don't use any harsh abrasive cleaners or sharp metal scrapers for cleaning the oven door. They could scratch the surface and destroy the glass. (Refer to the cleaning and maintenance section)

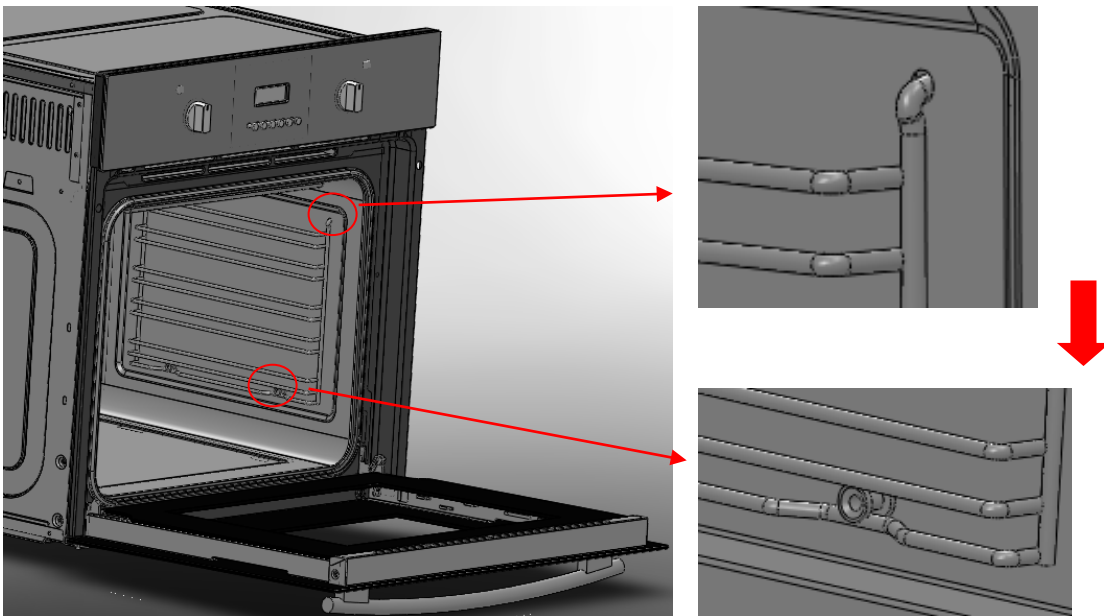

## Detaching and attaching the oven door

For cleaning purposes and to remove the door panels, you can detach the oven door.

Each hinge has a locking rod. When the locking rod is closed, the door is installed well and you can't move the door.

**CAUTION:** Before the hinge is totally locked, the locking rod may close suddenly. Ensure the locking rod is open when you are removing the door.

### Detaching the door

- 1) Completely open the door.
- 2) Push the locking rod upward.
- 3) Close the door. Hold the door at the two sides.  
Close the door more closely. Pull the door upwards, then downwards, and then pull out the door.

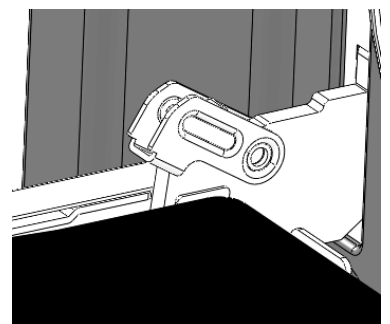

## Installing the door

- 1) Hold the door and insert the hinges into the holes.
- 2) Ensure the hinge is connected correctly then close the door.
- 3) Open the door and press the locking rod downward.
- 4) Close the door.

**Caution:** Don't touch the hinges with your hands. It could cause injury.

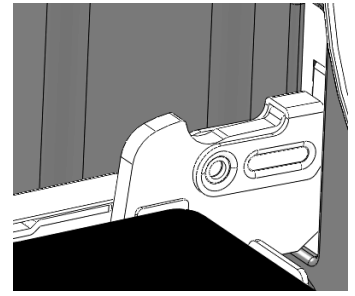

## How to remove the glass of the door

### Disassembly

- 1) Detach the door as per previous instructions.
- 2) Place the door handle side down on a cloth to prevent scratches.
- 3) With one hand underneath, push the glass upwards. At the same time use your other hand to pull the glass up from the door. After the glass is pulled out, horizontally remove the glass completely.

WARNING: Handle glass with care.

CAUTION: Don't use scraper or corrosive liquid to clean the door.

### Assembly

- 1) Insert the inner glass into the punch slot.
- 2) Press the inner glass.
- 3) Ensure the inner glass is fixed well before you put the door back to the oven.

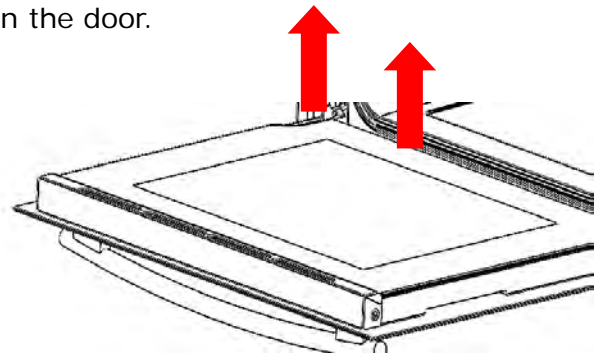

## Lamp Replacement

(If the bulb in the oven light fails, it must be replaced.)



**WARNING!** To avoid the possibility of an electric shock ensure that the appliance is switched off before replacing the bulb.

- 1) Disconnect all power from the appliance.
- 2) Place a tea towel in the oven when it is cold to prevent damage.
- 3) Unscrew the glass cover by turning it anti-clockwise.
- 4) Replace the bulb with one of the same type.
- 5) Screw the glass cover back in.
- 6) Remove the tea towel and reconnect the power.

## AVOIDING DAMAGE FROM MISUSE

- Only allow the cooking compartment to cool when it is closed. Even if the appliance door is only open a little, front panels of adjacent units could be damaged over time.
- If the door seal is very dirty, the appliance door will no longer close properly when the appliance is in use. The fronts of adjacent units could be damaged. Always keep the door seal clean.
- Do not sit on the appliance door, or place or hang anything on it. Do not place any cookware or accessories on the appliance door.
- Do not place accessories on the cooking compartment floor. Do not cover the cooking compartment floor with any sort of foil or greaseproof paper. Do not place ovenware on the cooking compartment floor if a temperature of over 50°C has been set. This will cause heat to accumulate. The baking and roasting times will no longer be correct and the enamel will be damaged.
- Do not pour water into the cooking compartment when it is hot. This will cause steam. The temperature change can cause damage to the enamel.
- Do not store moist food in the cooking compartment when it is closed for prolonged periods this will damage the enamel.
- When baking particularly juicy fruit pies, do not pack the baking tray too generously. Fruit juice dripping from the baking tray leaves stains that cannot be removed. If possible, use the deeper universal pan.
- Accessories can scratch the door panel when closing the appliance door. Always insert the accessories into the cooking compartment as far as they will go.
- Do not carry or hold the appliance by the door handle. The door handle cannot support the weight of the appliance and could break.

# INSTALLATION



The installation must be carried out by a suitably qualified person, in accordance with the with the manufacturer's instructions, and in accordance with all local electrical and building rules and specifications.

## Before Installation

The appliance is intended for installation into kitchen cabinet or enclosure, it is important to follow instructions to ensure correct installation. Improper installation will void the product warranty, and invalidate any claims.

- Ensure that the benchtop and oven cavity are completely square and level, and are to the required specification.
- Check that the oven door will be able to open fully without obstruction.
- **IMPORTANT:** The adjacent furniture or housing and all materials used in the installation must be able to withstand a minimum temperature of 85°C above the ambient temperature of the room it is located in, whilst in use.
- Certain types of vinyl or laminate kitchen furniture are particularly prone to heat damage or discolouration at temperatures below the guidelines given above.
- Kitchen cabinets must be set level and fixed. A gap of 5 mm is required between the appliance and surrounding unit fronts.
- Any damage caused by the appliance being installed in contravention of this temperature limit, or by placing adjacent cabinet materials closer than 5mm to the appliance, will be the liability of the owner.
- If there is a drawer beneath the oven, a shelf must be installed between oven and drawer.
- Keep all ventilation slots clear of obstructions.
- Carry the appliance with at least two persons, appliance is heavy and requires two persons lift
- **CAUTION!** The door and/or handle must not be used for lifting or moving the appliance, use the slots or wire handles located at both sides to move the appliance.
- **DO NOT** seal the installed oven with silicon or glue, as this will interfere with future maintenance

## Electrical Connection

Before connecting the appliance, make sure that the supply voltage marked on the Rating Plate corresponds with your mains supply voltage.

**WARNING:** this appliance must be earthed.

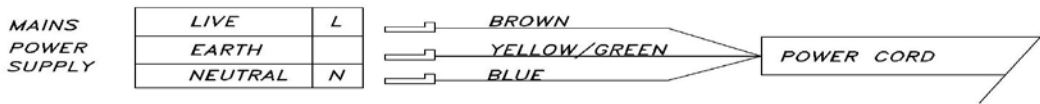

- A suitable disconnection switch is to be incorporated in the permanent wiring, the switch is to be of approved type and positioned in accordance with local wiring and electrical rules and specifications. The switch must have 3 mm air gap contact separation in all poles, in the active (phase) conductor of the fixed wiring.
- To connect the oven power cord, loosen and remove the cover on the terminal block, in order to gain access to the contacts inside. Make the connection, securing the cord in place with the cable clamp provided and then immediately close the terminal block cover again.
- If you have to change the oven power cord, the earthing (yellow/green) conductor must always be 10 mm longer than the line conductors.
- The installation must include 1.5m of free cable within the enclosure for ease of installation and future maintenance.
- The mains cable must not touch any hot metal.
- Care must be taken to ensure that the temperature of the mains supply cable does not exceed 50°C.
- If the mains supply cable is damaged, then it must be replaced by an appropriate replacement which can be obtained from the Spares Department.

## Installing the oven into the kitchen cabinet

The kitchen area should be dry and aired and equipped with efficient ventilation. When installing the oven, easy access to all control elements should be ensured.

Follow Figure 1 or 2 for installation.

- Ensure that the cabinet cavity is as required.
- Follow required ventilation requirements depending on installation.
- Ensure that the rear panel of the furniture housing unit has been removed.
- Ensure that the oven has been securely fixed into the housing unit. The fixing of the oven into the housing is secured with screws. These should be screwed through the oven cabinet and into the housing unit.
- DO NOT seal the installed oven with silicon or glue, as this will interfere with future maintenance.

**FIGURE 1**

Option for installation

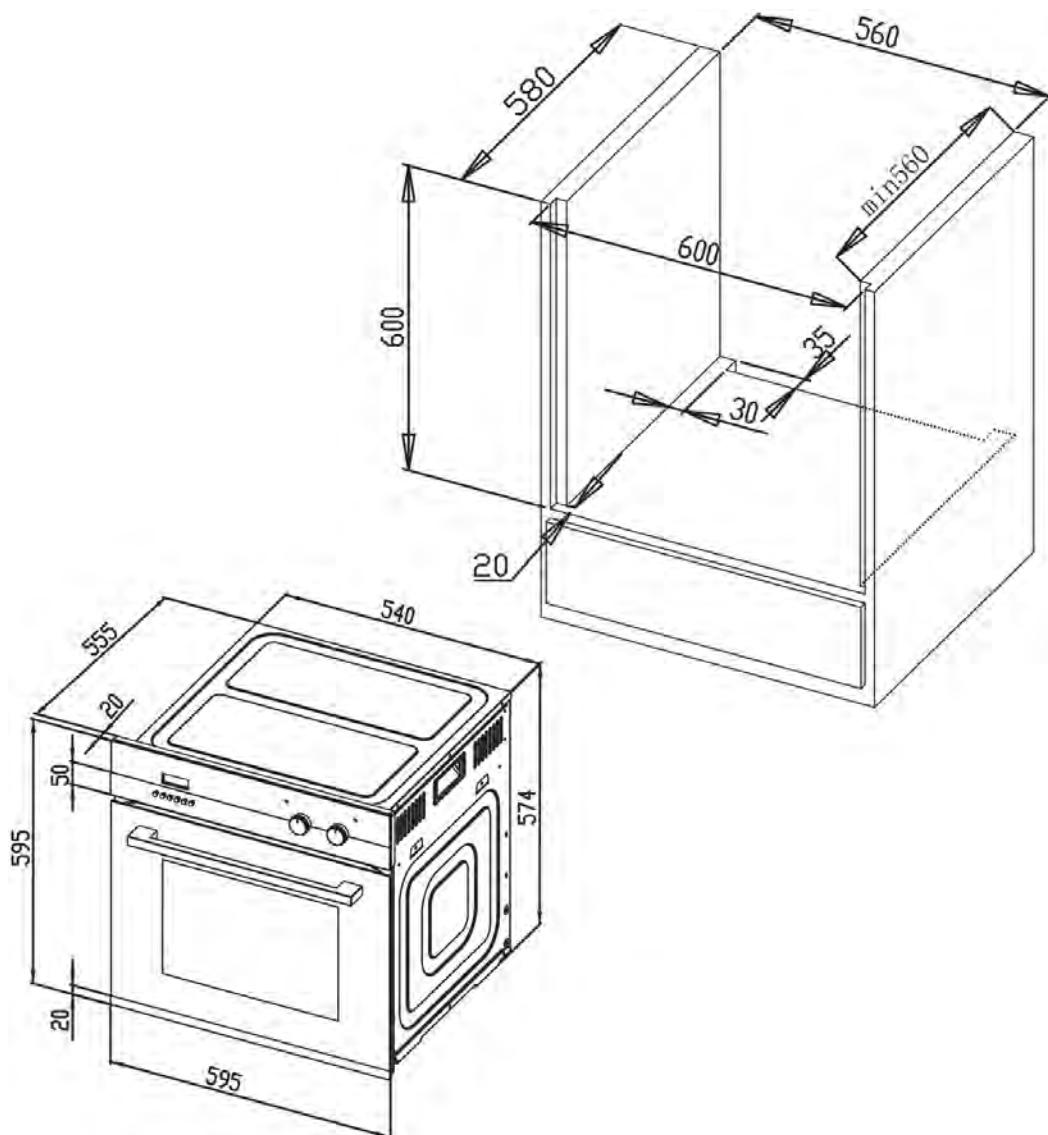

**FIGURE 2**

Option for installation

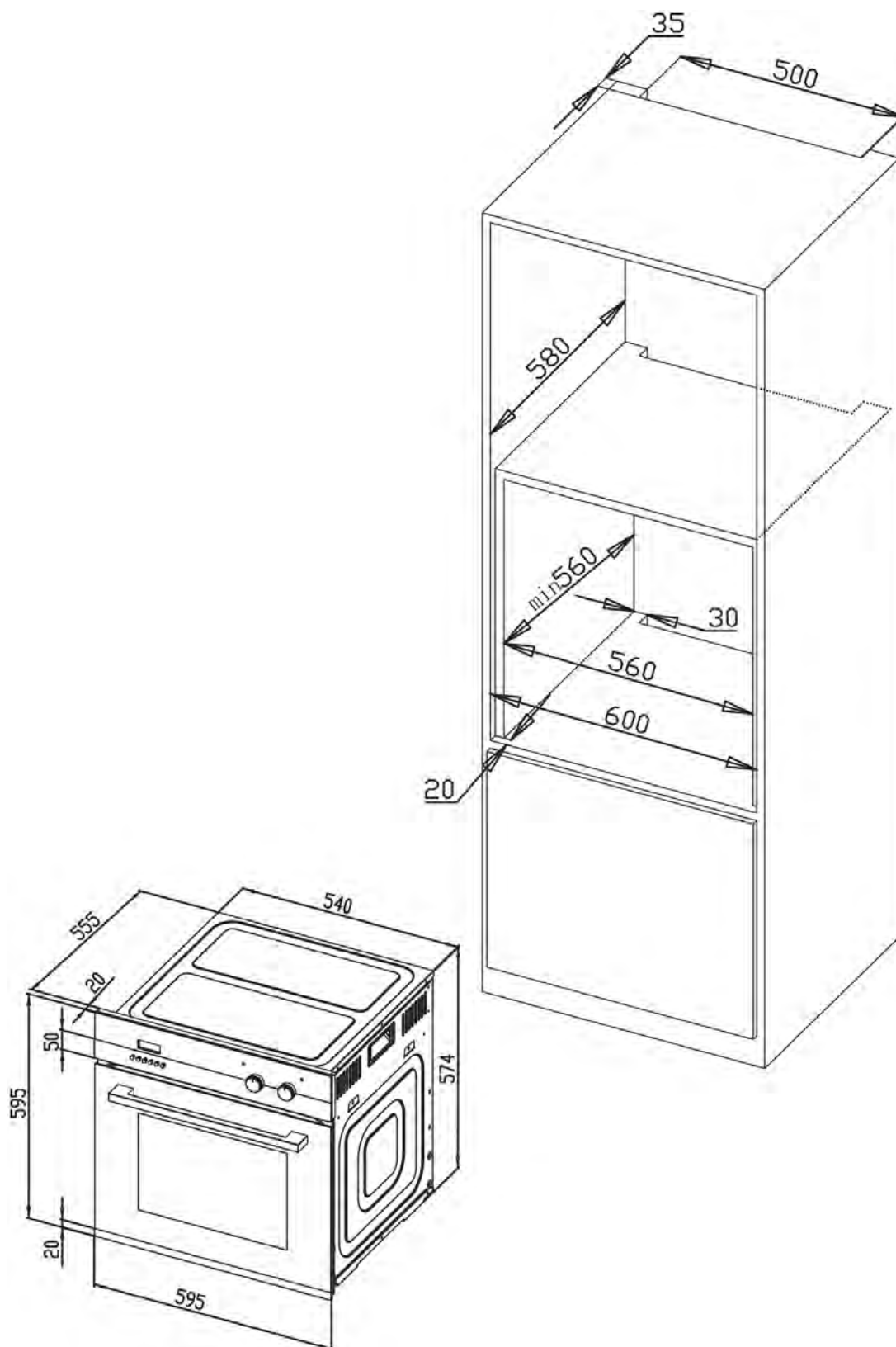



## Securing/Fixing Installation

1. Slide the oven through the cabinet aperture, align and secure.
2. Fix your oven with the 2 screws and washers as indicated in the figure.

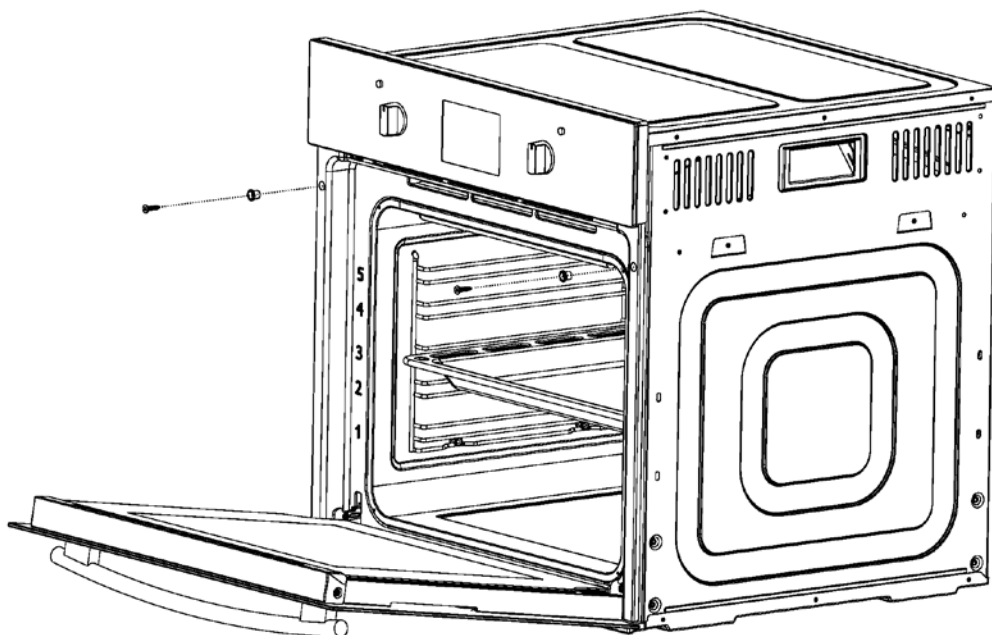

## Final Check

1. Connect the appliance to the mains supply and switch on the mains supply.
2. Check function.

## Ventilation requirements

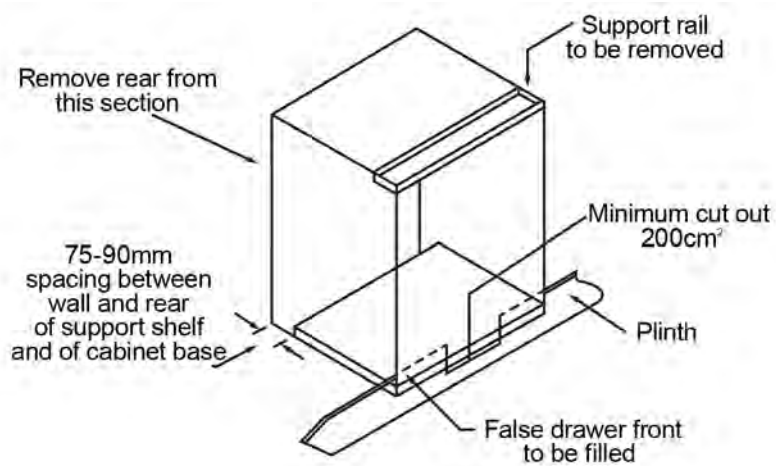

Figure above shows the ventilation and cut-out requirements for the installation of the appliance into a standard kitchen unit

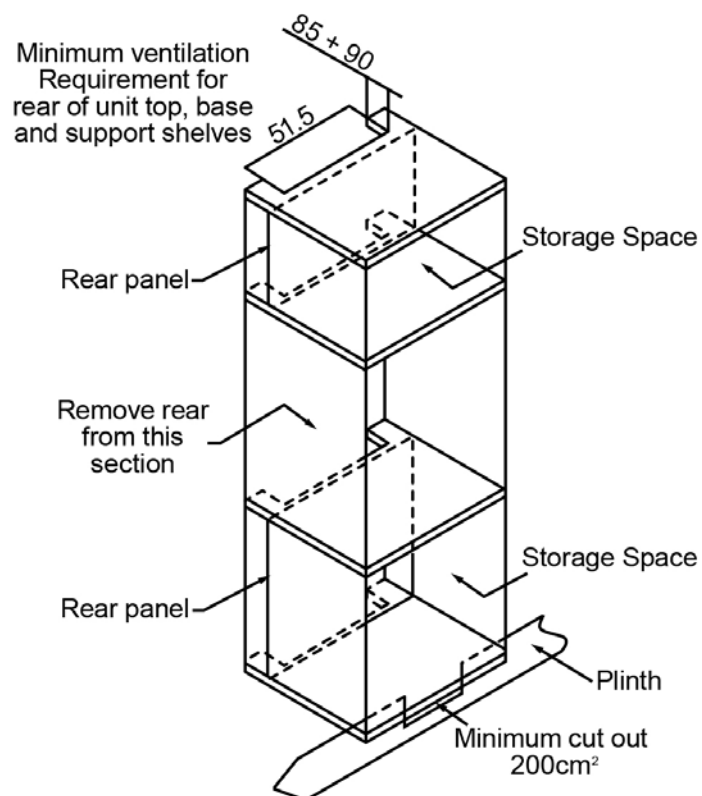

Figure shows the ventilation and cut-out requirements for the installation of the appliance into a tall housing unit

## TROUBLESHOOTING

If you are currently experiencing a malfunction or an error, before you call the technical department, please read the below information first. These are common troubleshooting problems, and may help resolve your issue.

- In the beginning hours of the first use, there may be smoke coming out of the oven. Please turn on the oven without cooking, until the smoke is gone.
- When the oven is heating, there may be cracking sounds due to the metal expanding.
- If you cook food with water, there may be steam coming out from the vent.
- If your oven has cooling fan, the cooling fan will start to work 15 minutes after heating, and it will stop 35 minutes after you turn off the oven.



**IMPORTANT:** If your appliance appears not to be operating correctly, please contact the dealer.

### **DO NOT ATTEMPT TO REPAIR THE APPLIANCE YOURSELF!**

Please note that if an Authorised Service Person is asked to attend whilst the product is under guarantee and finds that the problem is not the result of an appliance fault, then you may be liable for the cost of the call out charge.

The appliance must be accessible to perform any necessary repair. If your appliance is installed in such a way that an engineer is concerned that damage will be caused to the appliance or your kitchen, then they will not complete a repair.

This includes situations where appliances have been tiled in, sealed in with sealant, have wooden obstructions placed in front of the appliance, like plinths. Or if any installation other than the one specified by our company has been completed.

**WARNING! DO NOT ATTEMPT TO REPAIR THE APPLIANCE YOURSELF!**

## Troubleshooting Table

Problem	Possible Cause	Suggestion
Oven is not turning on	Power failure	Check the power in the house
	Failure of circuit breaker	Check the fuse
	Timer not set	Reset the timer
	Manual Operation	Check oven is in manual operation mode
Lamp is not working	Lamp is broken	Change the lamp
	Power failure	Check the power to the oven
Oven stops heating	Power failure	Check the power in the house
	Normal closed thermostat is reacting	If the cooling fan works normally, the Normal closed thermostat may be broken. Change it
	Timer has ended	Reset the timer
Oven cannot heat	Temperature is not set	Reset the temperature
	Cooking function not set	Select a cooking function
	Manual Operation	Check the oven in in manual operation mode
	Timer not set	Set the timer
	Power failure	Check the fuse
	Heating element is broken	Change the heating element
Grill and top element not working	Cooking function	Check the cooking function is correct
	Temperature of oven too high	Allow the oven to cool for 2 hours. Check again
Water drips when oven is working	The seal is broken	Change the seal
	Hinge is not working well	Change the hinge
Cooling fan keeps operating for a long time after the oven is turned off	The cooling fan lasts according to the heating period	If the venting air is hot, the cooling fan is working normally
	Normal on thermostat is broken	If the venting air is cool, change the normal on thermostat
Food not cooking properly	Cooking temperature	Check the cooking temperature is correct for the food you are cooking. Adjust the temperature +/- 10°C
	Cooking function	Check the cooking function is correct for the food you are cooking
Food is not cooking evenly	Oven is not installed correctly	Check the oven is installed correctly and level
	Temperature/Function	Check the correct temperature/function is being used
	Shelf position	Check the correct shelf position is being used

If the problem has not been solved, call the after-sales service of your store /dealer.

# COOKING RECOMMENDATIONS

## Tips for Energy Saving

The following information will help you to use your appliance in an ecological way, and to save energy:

- Use dark colored or enamel coated cookware in the oven, the heat transmission will be better.
- While cooking your dishes, perform a preheating operation if it is advised in the user manual or cooking instructions.
- Do not open the door of the oven frequently during cooking.
- Try to cook more than one dish in the oven at the same time, whenever possible. You can cook by placing two cooking vessels onto the wire grill.
- Cook dishes subsequently. The oven will already be hot.
- You can save energy by switching off your oven a few minutes before the cooking time. Do not open the oven door.
- Defrost frozen food before cooking.

## Tips for Baking

- Use non-stick coated appropriate metal plates, aluminum containers or heat-resistant silicone moulds.
- It is recommended to place the baking mould in the middle of the rack.
- How to establish whether sponge cake is baked through. Approximately 10 minutes before the end of the baking time specified in the recipe, stick a cocktail stick into the cake at the highest point. If the cocktail stick comes out clean, the cake is ready.
- The cake collapses. Use less fluid next time or set the oven temperature 10 degrees lower. Observe the specified mixing times in the recipe.
- The cake has risen in the middle but is lower around the edge. Do not grease the sides of the spring form cake tin. After baking, loosen the cake carefully with a knife.
- The cake goes too dark on top. Place it lower in the oven, select a lower temperature and bake the cake for a little longer.
- The cake is too dry. When it is done, make small holes in the cake using a cocktail stick. Then drizzle fruit juice or an alcoholic beverage over it. Next time, select a temperature 10 degree higher and reduce the baking time.
- The bread or cake (e.g. cheesecake) looks good, but is soggy on the inside (sticky, streaked with water). Use slightly less fluid next time and bake for slightly longer at a lower temperature. For cakes with a moist topping, bake the base first. Sprinkle it with almonds or bread crumbs and then place the topping on top. Please follow the recipe and baking times.
- The cake is unevenly browned. Select a slightly lower temperature to ensure that the cake is baked more evenly. Bake delicate pastries on one level using Top/bottom heating. Protruding greaseproof paper can affect the air circulation. For this reason, always cut greaseproof paper to fit the baking tray.
- The bottom of a fruit cake is too light. Place the cake one level lower the next time.
- The fruit juice overflows. Next time, use the deeper universal pan, if you have one.
- Small baked items made out of yeast dough stick to one another when baking. There should be a gap of approx. 2 cm around each item. This gives enough space for the baked items to expand well and turn brown on all sides.

- You were baking on several levels. The items on the top baking tray are darker than that on the bottom baking tray. Always use 3D hot air to bake on more than one level. Baking trays that are placed in the oven at the same time will not necessarily be ready at the same time.
- Condensation forms when you bake moist cakes. Baking may result in the formation of water vapour, which escapes above the door. The steam may settle and form water droplets on the control panel or on the fronts of adjacent units. This is natural process.

## **Tips for Grilling**

Grilling is ideal for cooking meat, fish and poultry and will achieve a nice brown surface without it drying out too much. Flat pieces, meat skewers and sausages are particularly suited for grilling as are vegetables with high water content such as tomatoes and onions.

- When grilling, preheat the oven for approx. 4 minutes, before placing the food into the cooking compartment. Always grill with the oven door closed.
- As far as possible, the pieces of food you are grilling should be of equal thickness. This will allow them to brown evenly and remain succulent and juicy.
- Turn the food you are grilling after 2/3 of the time.
- Do not add salt to steaks until they have been grilled.
- Add in a little liquid if the meat is lean. Cover the base of the ovenware with approx. 1/2 cm of liquid.
- Add liquid generously for pot roasts. Cover the base of the ovenware with approx. 1-2 cm of liquid.
- Place the food to be grilled directly on the wire rack. If you are grilling a single piece, the best results are achieved by placing it in the centre of the wire rack. The universal pan should also be inserted at level 1. The meat juices are collected in the pan and the oven is kept cleaner.
- When grilling, do not insert the baking tray or universal pan at level 4 or 5. The high heat distorts it and the cooking compartment can be damaged when removing it.
- The grill element switches on and off continually. This is normal. The grill setting determines how frequently this will happen.

## **Tips for Roasting**

- Seasoning with lemon juice and black pepper will improve the cooking performance when cooking a whole chicken, turkey or a large piece of meat.
- Meat with bones takes about 15 to 30 minutes longer before it is cooked than a roast of the same size without bones.
- You should calculate about 4 to 5 minutes cooking time per centimeter height of the meat.
- Let meat rest in the oven for about 10 minutes after the cooking time. The juice is better distributed all over the roast and does not run out when the meat is cut.
- Fish in a fire-resistant dish should be placed on the rack at the medium or lower level.
- When the roast is ready, turn off the oven and allow it to rest for an additional 10 minutes. This allows better distribution of the meat juices.
- For roast pork with a rind, score the rind in a crossways pattern, then lay the roast in the dish with the rind at the bottom.

- Place whole poultry on the lower wire rack breast-side down, turn after 2/3 of the specified time.
- For duck or goose, pierce the skin on the underside of the wings. This allows the fat to run out.
- How to tell when the roast is ready. Use a meat thermometer (available from specialist shops) or carry out a "spoon test". Press down on the roast with a spoon. If it feels firm, it is ready. If the spoon can be pressed in, it needs to be cooked for a little longer.
- The roast is too dark and the crackling is partly burnt. Check the shelf height and temperature.
- The roast looks good but the juices are burnt. Next time, use a smaller roasting dish or add more liquid.
- The roast looks good but the juices are too clear and watery. Next time, use a larger roasting dish and use less liquid.
- Steam rises from the roast when basted. This is normal and due to the laws of physics. The majority of the steam escapes through the steam outlet. It may settle and form condensation on the cooler switch panel or on the fronts of adjacent units.

# TECHNICAL DATA

## Specifications

<b>Voltage/frequency</b>	220-240V~50Hz
<b>Amps</b>	10.42 (A)
<b>Total power consumption</b>	2.3KW
<b>Cable type/section</b>	H05VV-F 3*1.5mm <sup>2</sup>
<b>Cable length</b>	1.5m
<b>External dimensions (height/width/depth)</b>	595/595/575(mm)
<b>Installation dimensions (height/width/depth)</b>	600/600/576(min)(mm)
<b>Main oven</b>	Multifunction oven
<b>Usable capacity of the oven</b>	65L
<b>Energy efficiency</b>	A+
<b>Oven lamp</b>	25W/300°C
<b>Grill power consumption</b>	2.25KW

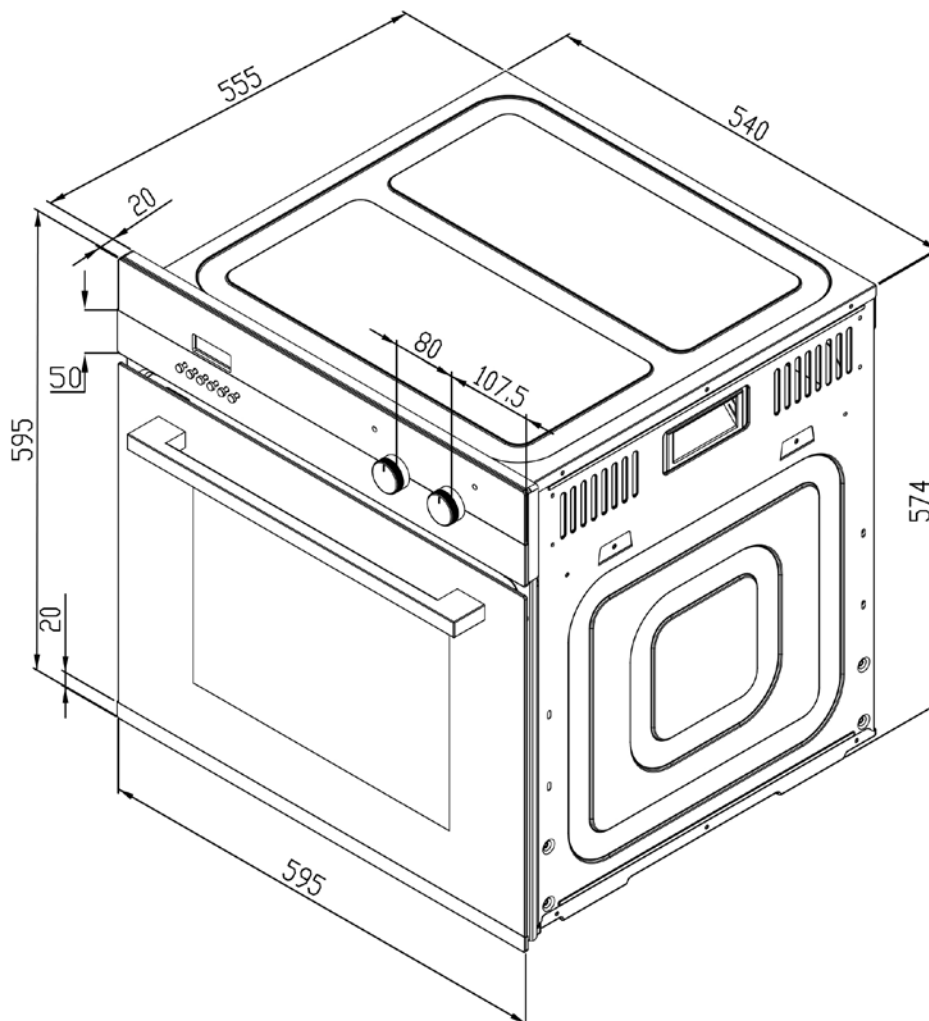



# DECLARATION OF CONFORMITY

## Australian Standards

This product has been designed and manufactured to comply with all relevant Australian and New Zealand Standards.

AS/NZS 60335.1 General Requirements for Domestic Electrical Appliances

AS/NZS 60335.2.6 Specific Requirements for Domestic Electrical Cooking Appliances

This appliance is SAA certified

Installation of the appliance must be only be undertaken by a licenced electrician who can provide a compliance certificate.

This appliance is intended for domestic use only.

## European Standards

- o *CE: Appliance conforming to the European directives 89/336/EEC, 93/68/EEC, 73/23/EEC and subsequent revisions and "RoHS" directive 2002/95/CE.\**
- o *The manufacturer declares that the oven is built using certified materials and requires the appliance to be installed in accordance with the standards currently in force. This appliance must be used by a trained person for domestic purposes only.*
- \* *The RoHS directive stands for "the restriction of the use of certain hazardous substances in electrical and electronic equipment". This directive bans the placing on the EU market of new electrical and electronic equipment containing more than the agreed levels of lead, cadmium, mercury, hexavalent chromium, polybrominated biphenyl (PBB) and polybrominated diphenyl ether (PBDE) flame retardants.*

European directive 2002/96/EC on Waste Electrical and Electronic Equipment (WEEE) (for European Union countries only)

This appliance is marked according to the European directive 2002/96/EC on Waste Electrical and Electronic Equipment (WEEE). By ensuring this product is disposed of correctly, you will help prevent potential negative consequences for the environment and human health, which could otherwise be caused by inappropriate waste handling of this product.

The symbol on the product, or on the documents accompanying the product, indicates that this appliance may not be treated as household waste. Instead it shall be handed over to the applicable collection point for the recycling of electrical and electronic equipment. Disposal must be carried out in accordance with local environmental regulations for waste disposal.

For more detailed information about treatment, recovery and recycling of this product, please contact your local city office or your household waste disposal service.